

Mitsubishi New Wind Turbines, MWT-1000A & MWT-S2000

YOSHINORI UEDA
HIDEHIKO ITAKA
KOSUKE INOUE

The capacity of wind power generation in Japan now exceeds 400 000 kW. Renewable Portfolio Standard (RPS), the law obliging the electric power suppliers to introduce renewable energy, was put into effect in April 2003, and the concerned ministries and agencies have begun to consider deregulation for wind power generation in ports and harbors, state-owned forests and parks. Government and business are united in promoting development of wind power generation with the aim of 3 000 000 kW by 2010. In view of this trend, Mitsubishi Heavy Industries, Ltd. (MHI) is developing new wind turbines. This paper introduces the development and operation of the 1 000 kW wind turbine MWT-1000A which was put into commercial operation in the United States in December 2002, and the MWT-S2000, Japan's first 2 000 kW class wind turbine.

1. Introduction

Against the global background of environmental protection, the world's wind power business is growing at an annual rate of over 30 percent (Fig. 1). In Japan, the total capacity had reached about 420 000 kW by the end of 2002. This movement is further encouraged by the institution of RPS and deregulation of harbors and state-owned forests.

MHI has been developing new wind turbines to meet such market needs and contributing to the solution of environmental problems in Japan. This paper introduces the high-performance 1 000 kW wind turbine MWT-1000A and Japan's first 2 000 kW class turbine MWT-S2000. Specifications are shown in Table 1.

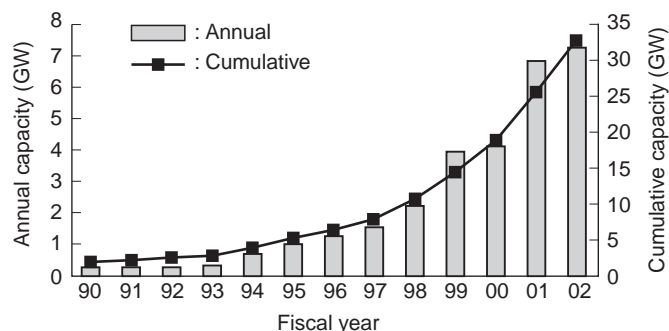

Fig. 1 Development of worldwide wind power generation

2. High performance 1 000 kW wind turbine MWT-1000A

2.1 Aim of development

This is a wind turbine developed in order to obtain sufficient power generation in regions of relatively low

Table 1 Comparison of new wind turbine and conventional wind turbine

Model	MWT-S2000 (large capacity wind turbine)	MWT-1000A (low wind speed turbine)	MWT-1000 (conventional wind turbine)
Rated output (kW)	2 000	1 000/250*	1 000/250*
Generator type	Permanent magnet synchronous generator	Induction generator (4-pole/6-pole)	Induction generator (4-pole/6-pole)
Estimated annual energy production (at annual average wind speed of 6 m/s)	About 2 times	22% increase	Reference
Rotor diameter (Blade length) (m)	75 (36)	61.4 (29.5)	57 (26.8)
Tower height (m)	60	60/68	60
Rotating speed (rpm)	8 to 24	19.8/13.2	21.0/14.0
Rated wind speed (m/s)	13.0	12.5	13.5
Cut-in wind speed (m/s)	2.5	2.5	3.5
IEC Wind class, annual average wind speed (m/s)	Class I 10.0	Class II 8.5	Class I 10.0

* : dual speed



Fig. 2 MWT-1000A
(Texas, United States)

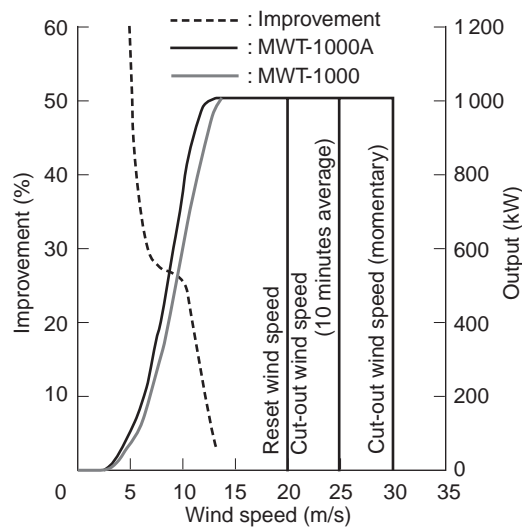

Fig. 3 Power curve of MWT-1000A

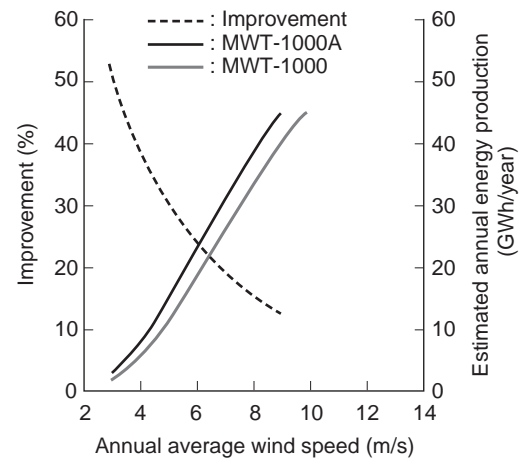

Fig. 4 Estimated annual energy production of MWT-1000A

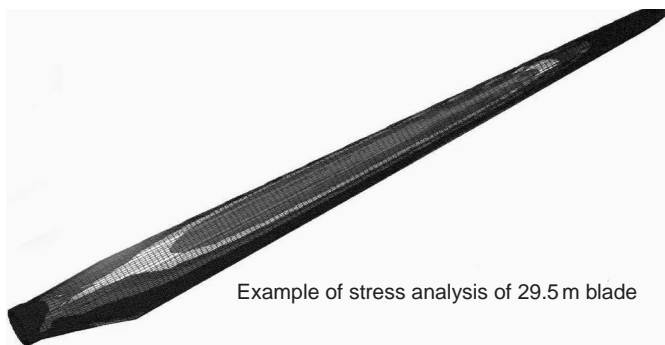

Fig. 5 Example of FEM analysis of 29.5 m blade



Fig. 6 Maximum load test of 29.5 m blade

wind speed (average wind speed of about 6 to 8 m/s), where existing wind turbines cannot be used profitably.

On the basis of the conventional 1 000 kW wind turbine of high reputation, 132 units of which have already been sold, the rotor diameter was extended by lengthening the blades from 26.8 m to 29.5 m, while output in the low wind speed region was improved by about 25% (Fig. 3). As a result, in the case of annual average wind speed of 6 m/s, the annual energy production has been increased by about 22% (Table 1, Fig. 4).

2.2 Design of new 29.5 m blades and strength test

Longer blades of 29.5 m were newly designed for use in the MWT-1000A in order to achieve high performance at low wind speed and to guarantee sufficient strength against the wind load on the turbine (Fig. 5). With the following design improvements, the weight of this blade is substantially unchanged despite extension of blade length.

- Improvement of internal structure of blade
- Improvement of blade material (glass fiber reinforced plastic)
- Improvement of structure of blade root

In trial blades, maximum load tests and fatigue tests were executed in the blade shop, and sufficient strength to withstand life-time use was confirmed (Fig. 6, Fig. 7).

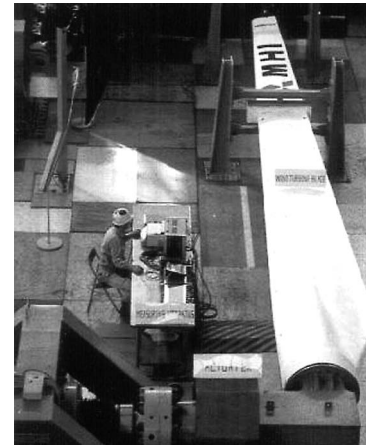

Fig. 7 Fatigue test of 29.5 m blade

2.3 Operation and performance test of first unit

Test operation of the first unit of MWT-1000A was conducted at White Deer Site, Texas, on December 26, 2002 (Fig. 2).

The performance was measured by a third party (National Renewable Energy Laboratory <NREL>) according to the rule of IEC61400, and the results are shown in Fig. 8. In all wind speed regions, a higher performance than planned was obtained.

The first unit of MWT-1000A for Japan is planned for installation at Seto Wind Hill, Ehime Prefecture, to start operation in October 2003.

3. 2,000 kW wind turbine MWT-S2000

3.1 Standing position of MWT-S2000

In Europe, wind turbines are rapidly increasing in size in view of offshore wind power generation (Fig. 9). In anticipation of larger size in the future, MHI has been continuing development (Fig. 10), and has constructed Japan's first 2 000 kW wind turbine for the Okinawa New Energy Development Company, Incorporated. Its feasibility run was started in February 2003 (Fig. 11).

This MWT-S2000 (see specifications in Table 1) is the latest model of Mitsubishi Synchronous Wind Turbines (S series) developed jointly with Mitsubishi Electric Corporation. This is the first 2 000 kW class wind turbine developed by a non-European manufacturer, and the world's largest commercial wind turbine using a permanent magnet synchronous generator.

Mitsubishi Synchronous Wind Turbines (S series) including the MWT-S2000 are highly evaluated for their technical creativity and low load to electric power grid system. Therefore they received the Minister of Economy, Trade and Industry Prize of New Energy Award 2002

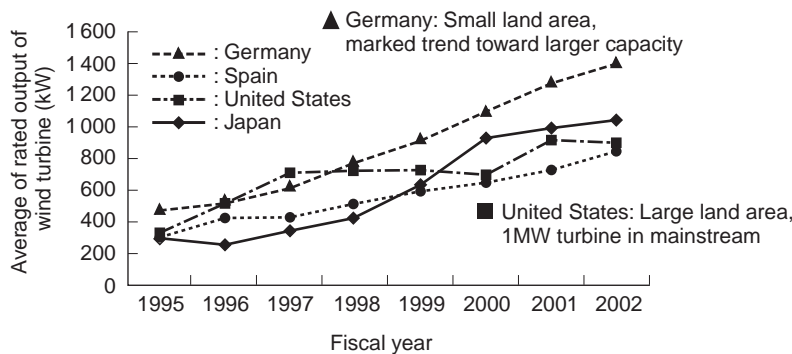

Fig. 9 Changes of average of wind turbine rated output (4)

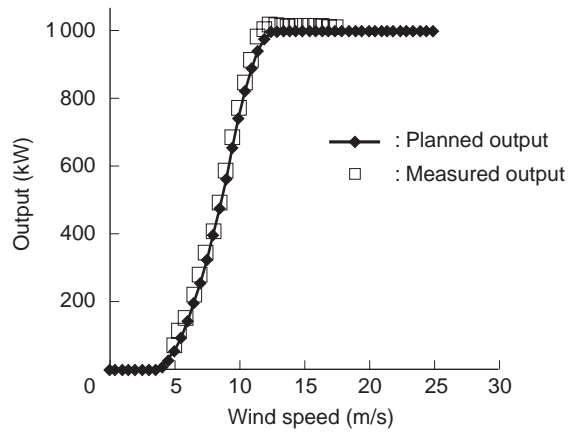

Fig. 8 Performance test results of MWT-1000A (Texas, United States, reported by NREL)



Fig. 11 Japan's first 2 000 kW wind turbine (MWT-S2000 at Gushikawa Power Station, Okinawa New Energy Development Co.)

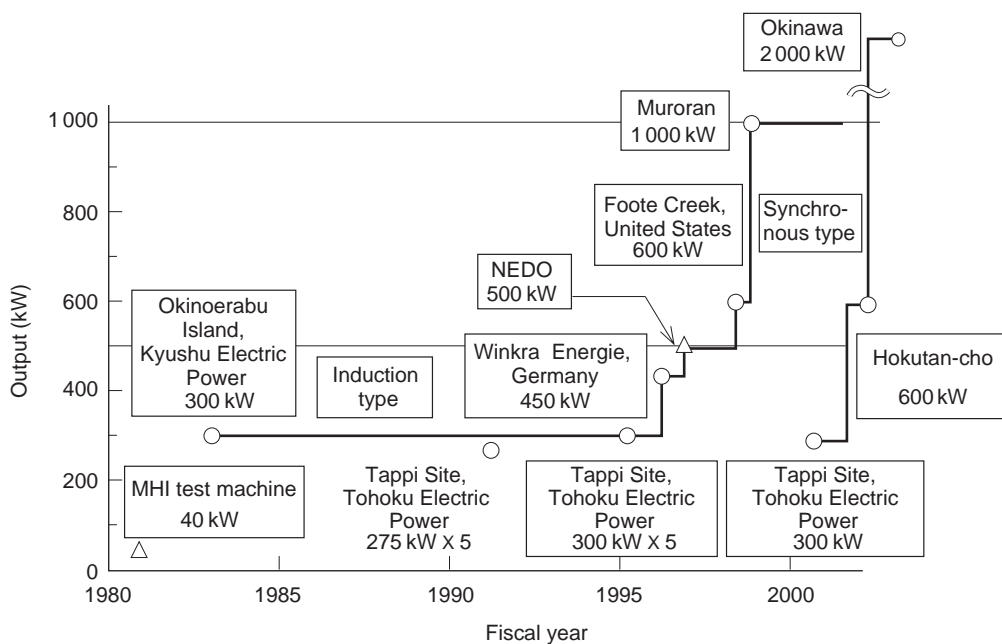

Fig. 10 History of development of Mitsubishi wind turbines



Fig. 12 Presentation ceremony of New Energy Award 2002 (Big Site, Tokyo, February 6, 2003).

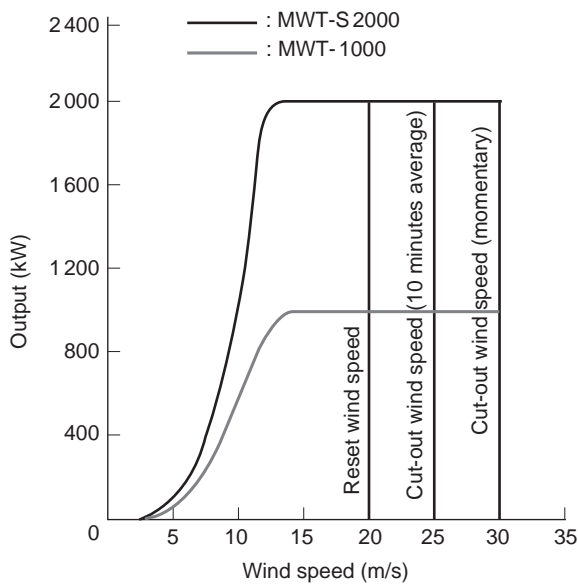

Fig. 14 Power curve of MWT-S2000

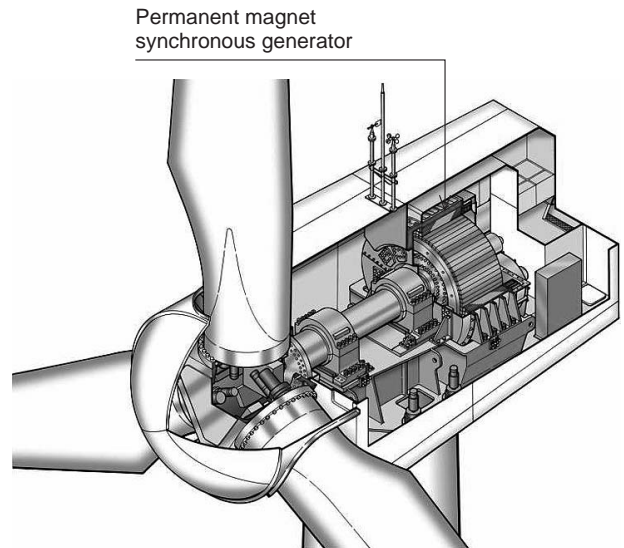

Fig. 13 Structure of MWT-S2000 (variable speed gearless synchronous wind turbine)

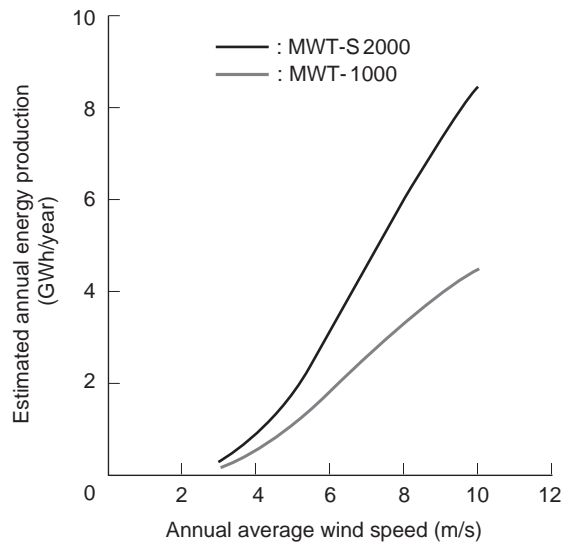

Fig. 15 Estimated annual energy production of MWT-S2000

from the New Energy Foundation on February 6, 2003 (Fig. 12).

3.2 Aim of development

From the commercial/strategical viewpoint, the MWT-S2000 was developed to satisfy demands in various markets including expecting single larger turbine, wind farms, and offshore needs exposed to stronger wind than on the land. The power curve and estimated annual energy production are shown in Fig. 14 and Fig. 15.

The rated output of 2000 kW was determined from the two viewpoints. One is global trend of commercial turbines and another is the wind turbine market of interconnection for weak utility grid (upper limit is 2 MW) in Japan.

The shape of the wind turbine (Table 1 and Fig. 13) was determined in consideration of restrictions on transportation and installation, and the strength of IEC Class I to withstand typhoons. In particular, due to severe traffic limitations in Japan (tunnels and pedestrian bridges), the diameter of the synchronous generator was limited to 4.2 m or less.

Thirdly, we chose the system of variable speed gearless permanent magnet synchronous wind turbine. MHI chose gearless structure for better reliability by simplifying the structure in order to apply to offshore wind power generation in the future. Synchronous generator can overcome fluctuations in generated power, which is the weak point in wind power generation.

3.3 Design and strength test of MWT-S2000

In gearless design, the rotating speed of the generator is lower, and there is a need to compensate by expanding the diameter and increasing the number of poles. European manufacturers solve these problems by employing generators of giant disk type for synchronous wind turbines, but in Japan transportation of such structures is impossible. By the following joint design efforts with Mitsubishi Electric Corporation, the large capacity synchronous generator has been successfully completed with a diameter of less than 4 m.



Fig. 16 Maximum load test of 36 m blade for 2 000 kW

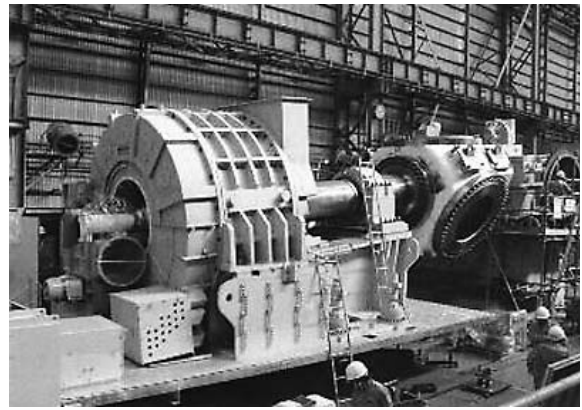

Fig. 17 Shop test of synchronous generator for 2000kW

- Potent neodymium magnet (10 times more powerful than ferrite)
- Reinforced cooling by mechanical draft
- Opposing configuration of rotor and generator (Fig. 13)

The 36 m blade and synchronous generator developed for the MWT-S2000 were tested and evaluated at the shop before being shipped to Gushikawa Power Station (Fig. 16, Fig. 17).

3.4 Installation and trial run

The first unit of the MWT-S2000 was installed on the dike of the Gushikawa Power Station of Okinawa Electric Power Company on January 24, 2003 (Fig. 11). The trial run started in February, it was transferred to the client at the end of March, and commercial operation began in April.

In the trial run, with the advantage of synchronous wind turbine, there was little output fluctuation. In performance evaluation, satisfactory results were obtained by the standard of nacelle anemometer, and more specific measurements are planned from now on by setting up reference meteorological stations.

4. Future outlook

In April 2003, commercial operation of Japan's first 2 000 kW wind turbine began in Okinawa, marking the debut of big wind turbines in Japan. For installation of very large wind turbines in Japan, aside from the development of the wind turbine itself, there are many problems to be solved in relation to the infrastructure:

- Transportation of long components: Wide, straight and flat roads for transporting blades about 40 m in length are needed.
- Installation crane: Giant cranes capable of lifting a nacelle weighing more than 100 tons to the top of a tower over 70 m high are needed at low cost.

In Japan, applications of 2 000 kW class wind turbines are limited to the very large fields of Hokkaido or port and harbor area with convenient transportation. Wide applications of large wind turbines in Japan are impos-

sible without development of new technology such as connecting techniques for large blades or offshore wind sites. For the time being, the mainstream seems to be the introduction of medium class wind turbines of 1 000 kW to 1 500 kW such as the MWT-1000A which are already recognized as having high technology and economic merits.

Triggered by the enforcement of RPS in April 2003, wind power development in Japan is accelerating, and large wind farms are being opened successively. MHI, the only giant wind turbine manufacturer in Japan, continues to offer novel techniques and new products while building up a bright future for harmony and balance between human beings and the environment.

References

- (1) Fujikawa et al., Mitsubishi High Efficiency Large Capacity Wind Turbines, Mitsubishi Heavy Industries Technical Review Vol.39 No.3 (2002)
- (2) Ueda, Y., Recent Trends about Wind Turbine Generator System, The Thermal and Nuclear Power (Aug. 2002)
- (3) Itaka, H., Ueda, Y., The First 2000 kW Wind Turbine in Japan, Eco Industry (Jul. 2003)
- (4) BTM Consults World Market Update 2002



POWER SYSTEMS HEADQUARTERS

Yoshinori Ueda

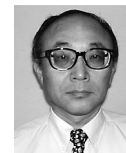

NAGASAKI SHIPYARD & MACHINERY WORKS

Hidehiko Itaka



POWER SYSTEMS HEADQUARTERS

Kosuke Inoue