

MODEL: BELLHOP 6
TYPE: ELECTRIC POWERED PERSONNEL CARRIER
MODEL YEAR: 2010

Part No.: 600918 *

** Same as Bellhop 4 with Rear Facing Seat option selected*



PRODUCT SPECIFICATION

CONFIGURATION HIGHLIGHTS

Precision Drive System™ (PDS): Factory programmable to application

- Solid State continuously variable separately excited speed controller
- Dash mounted direction selector switch (Forward-Neutral-Reverse)
- Anti-roll back, walkaway braking and alarm
- Anti-stall motor protection
- Regenerative 'Pedal Down' and/or 'Pedal Up' braking
- Eight, 6 Volt Deep Cycle
- Full torque, reduced speed reverse
- Inductive throttle sensor
- Diagnostic indicator
- Factory selectable performance options

Battery Charger: Delta Q, 48 VDC. H120/230 VAC 50/60 Hz. Underwriters Laboratories (U.L.) Listed, (C.S.A. Certified)
Motor: 48 volt DC shunt wound, brazed armature, solid copper windings. Intermittant Horsepower 18.1 hp (13.5 kW) at 1900 rpm (1hour)
Drive Train: Direct motor shaft connected to transaxle pinion shaft
Electrical System: 48 Volt DC, eight, 6 volt deep cycle storage batteries (107 minute, 225 amp-hour @ 20 hr. discharge rate)
Transaxle: Differential with helical gears
Brakes: Dual rear wheel mechanical self-adjusting drum brakes. Automatic single point park brake release with self-compensating system

PRODUCT OVERVIEW

Dimensions	
Overall Length	133.0 in (338 cm)
Overall Width	46.5 in (119 cm)
Overall Height (No Canopy)	48.6 in (123 cm) (Top of steering wheel)
Overall Height (With Canopy)	72.0 in (183 cm)
Wheel Base	93.5 in (237 cm)
Front Wheel Track	34.2 in (86.7 cm)
Rear Wheel Track	38.0 in (97 cm)
Gnd Clearance @ Differential	4.3 in (11 cm)

Performance	
Seating Capacity	6 Person
Dry Weight	710 lb (320 kg) (Without Batteries)
Curb Weight	1200 lb (540 kg)
Vehicle load capacity	1198 lb (540 kg)
Outside Clearance Circle	25.5 ft (7.8 m)
Speed (Level Ground)	13 mph ± 0.5 mph (21 kph ± 0.8 kph)
Intersecting Aisle Clearance	94.0 in (240 cm)

Vehicle Power	
Power Source	48 Volts DC
Motor Type	Shunt Wound
Continuous Horsepower (kW)	2.5 hp (1.9 kW)
Intermittent Horsepower (kW)	18.1 hp (13.5 kW) @ 1900 rpm
Electrical System	48 Volt
Batteries (Qty, Type)	Eight, 6 Volt Deep Cycle
Key or Pedal Start	Pedal Start
Battery Charger	48 VDC Delta Q, 120/230 VAC, UL & CSA
Speed Controller	400 Amp Precision Drive System (PDS)
Drive Train	Motor Shaft Direct Drive
Transaxle	Differential with helical gears
Gear Selection	Dash Mounted Forward-Neutral-Reverse
Rear Axle Ratio	14.7:1

Steering & Suspension	
Steering	Self-compensating rack and pinion
Front Suspension	Leaf springs with hydraulic shock absorbers
Rear Suspension	Leaf springs with hydraulic shock absorbers
Service Brake	Rear wheel mechanical self-adjusting drum
Parking Brake	Self-compensating, single point engagement
Front Tires	Links 18 x 8.50 - 8 (4 Ply Rated)
Rear Tires	Links 18 x 8.50 - 8 (4 Ply Rated)

Body & Chassis	
Frame	Welded steel. DuraShield™ powder coat
Body & Finish	Injection molded TPO
Seat Pod	Fiberglass & Gelcoat
Standard Color	Champagne

Some items shown may be optional equipment

OPTIONS & FIELD INSTALLED ACCESSORIES (Installation not included)*

Item	Std	Opt	Fld	Item	Std	Opt	Fld
TIRES & WHEELS:				Miscellaneous Electrical:			
Front:				Horn			
Links 18 x 8.50 - 8 (4 Ply Rated)	●			State of Charge Meter	●		
USA Trail 18 x 8.50 - 8 (Load Range C)		●		DC Converter (20 Amp)		●	
Rear:				Hour Meter			
Links 18 x 8.50 - 8 (4 Ply Rated)	●			Individual Key Switch		●	
USA Trail 18 x 8.50 - 8 (Load Range C)		●		Unique Group Key Switch		●	
Wheel Covers:				WEATHER PROTECTION:			
Spoke, Black & Gold		●		Sun Canopy 118 in (300 cm) (Beige)			●
Spoke, Black & Silver		●		Sun Canopy 118 in (300 cm) (White)			●
Chrome 8 in (20 cm)		●		Windshield Flat			●
COLORS:				Windshield Fold Down			
Champagne Body	●			ADDITIONAL OPTIONS & FIELD INSTALL ACCESSORIES			
Hunter Green Body		●		Ash Tray		●	
Bright White Body		●		Rear View Mirror (Sun Canopy Required)			●
Black Body		●					
Flame Red Body		●					
Yellow Body		●					
Pin Stripes:							
Gold		●					
Dark Green		●					
White		●					
Black		●					
Burgundy		●					
Non Standard Color		●					
Seating:							
Oyster Seats	●						
Tan Seats		●					
Gray Seats		●					
White Seats		●					
VEHICLE PERFORMANCE							
Hydraulic Front Disc Brakes		●					
ELECTRICAL:							
Battery Chargers:							
48 VDC PowerWise™, 120 VAC, UL & CSA	●						
48 VDC PowerWise™, 230 VAC, 50 Hz		●					
48 VDC Delta-Q, 10 ft (3 m) DC Cord		●					
48 VDC Delta-Q, 18 ft (5.5 m) DC Cord			●				
Battery Charger Delete		●					
Batteries:							
Trojan T105	●						
Trojan T145 Lo-Profile		●					
Lighting							
Headlights		●					
Tail Lights		●					
Brake Lights		●					
Turn Signals with 4-Way Flashers		●					

DIMENSIONS

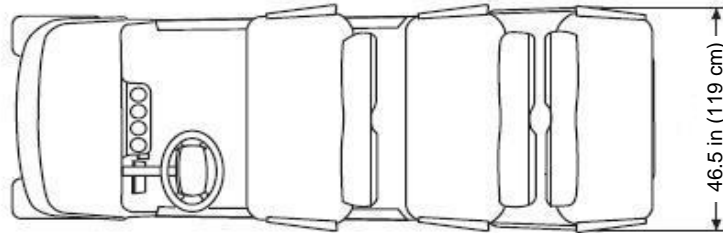
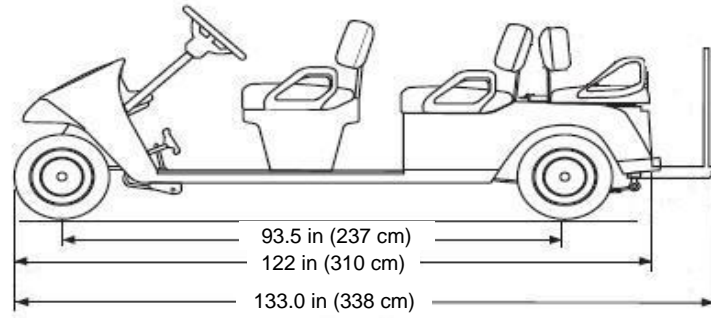
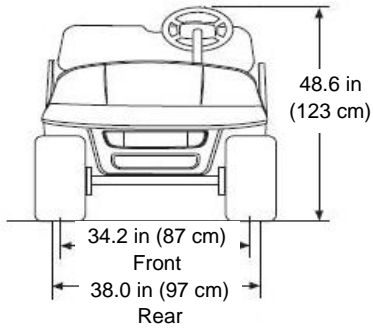

CLEARANCE DIAGRAMS

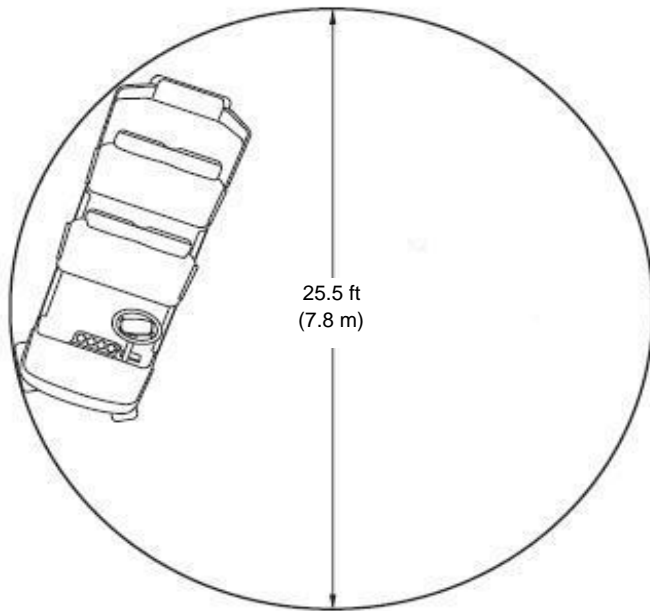

TURNING CLEARANCE DIAMETER

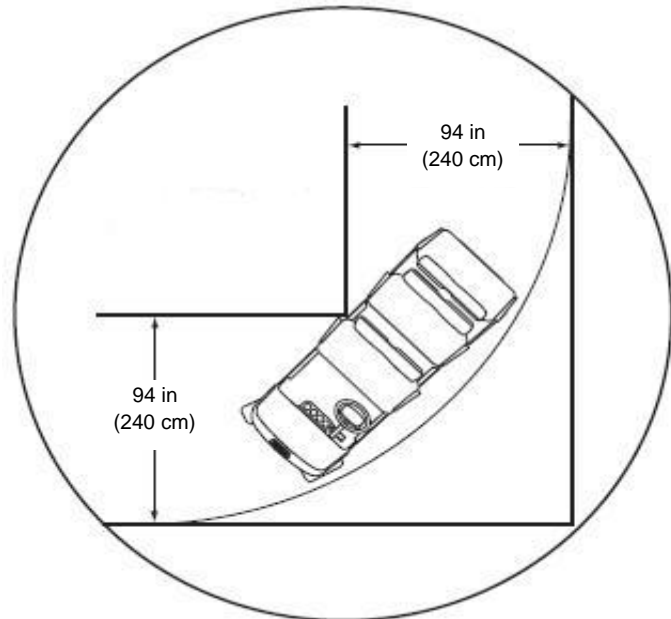

INTERSECTING AISLE CLEARANCE

MODEL: BELLHOP 6
TYPE: GAS POWERED PERSONNEL CARRIER
MODEL YEAR: 2010
Part No.: 605783*, 606679* California



* Same as Bellhop 4 with Rear Facing Seat option selected

PRODUCT SPECIFICATION

CONFIGURATION HIGHLIGHTS

- Engine:** 13 hp (9.7 kW) Exceeds SAE J1940 Standard, 4 cycle, 24.5 ci (401 cc) single cylinder, air-cooled by Kawasaki
- **Valve Train:** Overhead valve
- **Lubrication:** Pressurized oil system, spin-on oil filter
- **Balancer:** Internal counter rotating balance shaft
- **Fuel System:** Fixed float bowl with remote pulse fuel pump
- **Ignition:** Electronic spark/magneto
- **Air Cleaner:** Replaceable dry cartridge
- Electrical:** Starter/Generator, solid-state regulator, 12 Volt maintenance free battery (425 CCA, 60 minute reserve)
- Drive Train:** Automatic, continuously variable transmission (CVT)
- Brakes:** Dual rear wheel mechanical self-adjusting drum brakes. Single point park brake release with self-compensating system
- Transaxle:** Differential with helical gears, ground speed governor, forward/reverse

PRODUCT OVERVIEW

Dimensions	
Overall Length	133.0 in (338 cm)
Overall Width	46.5 in (119 cm)
Overall Height (No Canopy)	48.6 in (123 cm) (Top of steering wheel)
Overall Height (With Canopy)	72.0 in (183 cm)
Wheel Base	93.5 in (237 cm)
Front Wheel Track	34.2 in (86.7 cm)
Rear Wheel Track	38.0 in (97 cm)
Gnd Clearance @ Differential	4.3 in (11 cm)

Performance	
Seating Capacity	6 Person
Dry Weight	886 lb (400 kg)
Curb Weight	926 lb (420 kg)
Vehicle load capacity	1200 lb (540 kg)
Outside Clearance Circle	25.5 ft (7.8 m)
Speed (Level Ground)	16 mph ± 0.5 mph (26 kph ± 0.8 kph)
Intersecting Aisle Clearance	94.0 in (240 cm)

Vehicle Power	
Power Source	4 Cycle 24.5 cu in (401 cc). Low Emission
Valve Train	Single Cylinder OHV
Horsepower (kW)	13 hp (9.7 kW) Exceeds SAE J1940 Std.
Electrical System	Starter/Generator. Solid State Regulator
Battery (Qty, Type)	One, 12 Volt Maintenance Free
Key or Pedal Start	Pedal
Air Cleaner	Industrial Rated Dry Filter
Lubrication	Pressurized Oil System
Oil Filter	Spin-On
Cooling System	Air Cooled
Fuel Capacity	5.8 Gallon (22.0 L) tank
Drive Train	Continuously variable transmission (CVT)
Transaxle	Differential with helical gears
Gear Selection	Forward - Reverse
Rear Axle Ratio	11.42:1 (Forward) 15.78:1 (Reverse)

Steering & Suspension	
Steering	Self-compensating reduction rack and pinion
Front Suspension	Leaf springs with hydraulic shock absorbers
Rear Suspension	Leaf springs with hydraulic shock absorbers
Service Brake	Rear wheel mechanical self-adjusting drum
Parking Brake	Self-compensating, single point engagement
Front Tires	Links 18 x 8.50 - 8 (4 Ply Rated)
Rear Tires	Links 18 x 8.50 - 8 (4 Ply Rated)

Body & Chassis	
Frame	Welded steel. DuraShield™ powder coat
Front & Rear Body & Finish	Injection molded TPO
Seat Pod & Finish	Fiberglass & Gelcoat
Standard Color	Champagne

Some items shown may be optional equipment

OPTIONS & FIELD INSTALLED ACCESSORIES (Installation not included)*

Item	Std	Opt	Fld	Item	Std	Opt	Fld
TIRES & WHEELS:				WEATHER PROTECTION:			
Front:				Sun Canopy (Top) Beige			
Links 18 x 8.50 - 8 (4 Ply Rated)	●			Sun Canopy (Top) White			●
USA Trail 18 x 8.50 - 8 (Load Range C)		●		Windshield Flat			●
Rear:				Windshield Fold Down			
Links 18 x 8.50 - 8 (4 Ply Rated)	●			OTHER OPTIONS & FIELD INSTALL ACCESSORIES			
USA Trail 18 x 8.50 - 8 (Load Range C)		●		Ash Tray		●	
Wheel Covers:				Rear View Mirror (Sun Canopy Required)			
Spoke, Black & Gold		●		VEHICLE CERTIFICATION KIT(S)			
Spoke, Black & Silver		●		CE Kit		●	
Chrome 8 in (20 cm)		●					
COLORS:							
Champagne Body	●						
Hunter Green Body		●					
Bright White Body		●					
Black Body		●					
Flame Red Body		●					
Yellow Body		●					
Pin Stripes:							
Gold		●					
Dark Green		●					
White		●					
Black		●					
Burgundy		●					
Non Standard Color		●					
Seating:							
Oyster Seats	●						
Tan Seats		●					
Gray Seats		●					
White Seats		●					
VEHICLE PERFORMANCE							
Hydraulic Front Disc Brakes		●					
High Altitude Jetting (3k-6k ft. & >6k ft.)		●					
Clutch Belt Shield			●				
ELECTRICAL							
Lighting:							
Headlights		●					
Tail lights		●					
Brake Lights		●					
Turn Signals with 4-way Flashers		●					
Miscellaneous Electrical:							
Horn	●						
Fuel Gauge with Low Oil Indicator	●						
Hour Meter		●					
Individual Key Switch		●					
Unique Group Key Switch		●					

DIMENSIONS

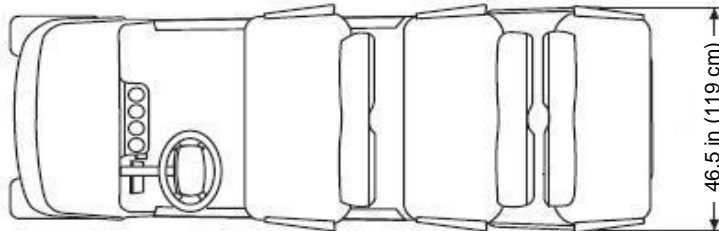
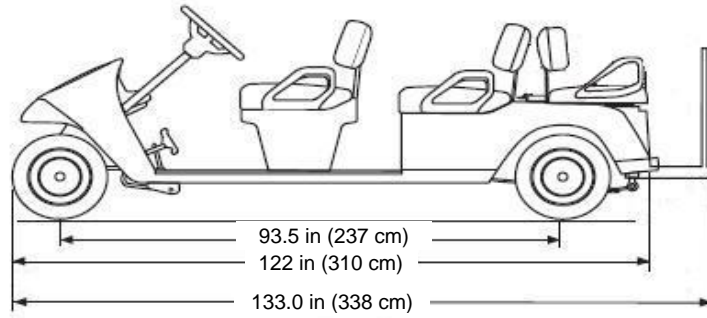
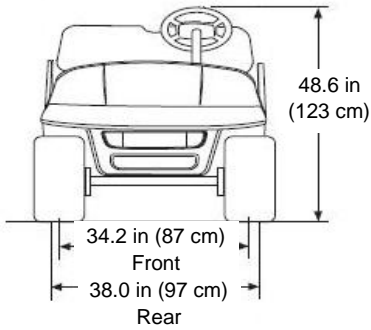

CLEARANCE DIAGRAMS

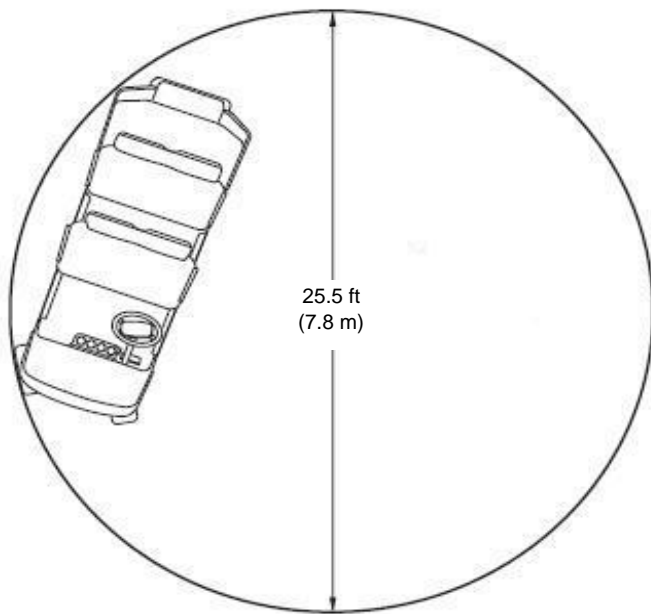

TURNING CLEARANCE DIAMETER

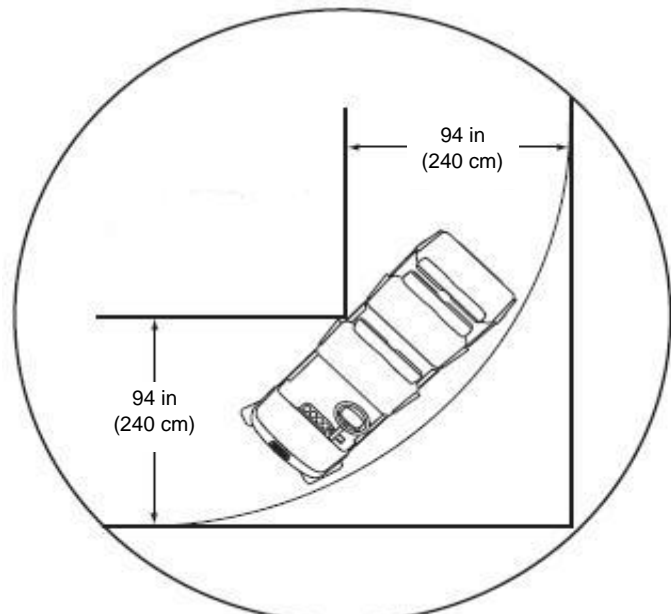

INTERSECTING AISLE CLEARANCE