

TSM-DC01A.05

THE SOLUTION IN BLACK

15.2%
MAX EFFICIENCY

195W
MAX POWER OUTPUT

10 YEAR
PRODUCT WARRANTY

25 YEAR
LINEAR POWER WARRANTY

Founded in 1997, Trina Solar is a vertically integrated PV manufacturer, involved in the production of ingots, wafers and cells to the assembly of high quality modules, using both mono and multi-crystalline technologies. As of July 2011, the Company has already achieved an annualized nameplate module capacity of approximately 1.9GW. Trina Solar's wide range of products are used in residential, commercial, industrial and public utility applications throughout the world.

Only by matching an efficient cost-structure with proven performance will we as an industry achieve grid parity. And at Trina Solar, we have both.

Trina Solar Limited
www.trinasolar.com



Module can bear snow loads up to **5400Pa** and wind loads up to **2400Pa**



Guaranteed power output **0~+3%**



High performance under low light conditions
Cloudy days, mornings and evenings



Optimized corners increase output up to **195W**



Independently certified by **international certification bodies**



Manufactured according to International Quality and Environment Management System Standards **ISO9001, ISO14001**

LINEAR PERFORMANCE WARRANTY

NEW

10 Year Product Warranty • 25 Year Linear Power Warranty

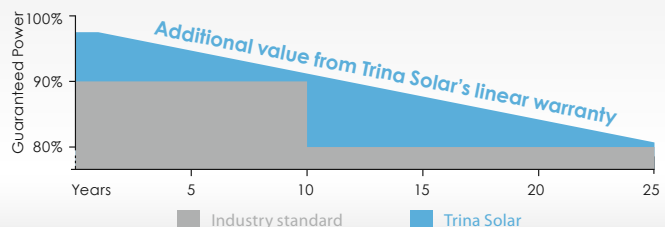

TSM-DC01A.05 THE SOLUTION IN BLACK

DIMENSIONS OF PV MODULE TSM-DC01A.05

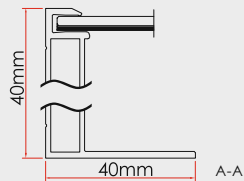
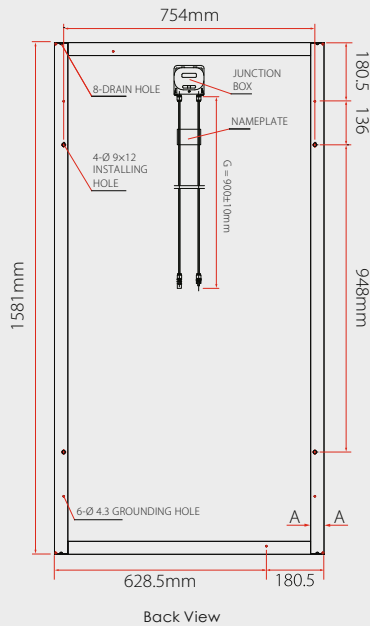

I-V CURVES OF PV MODULE TSM-190 DC01A.05

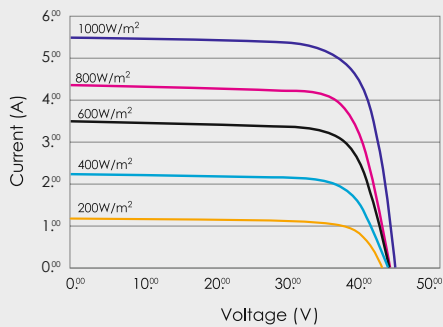

Average efficiency reduction of 4.5% at 200W/m² according to EN 60904-1.

CERTIFICATION



ELECTRICAL DATA @ STC	TSM-185 DC01A.05	TSM-190 DC01A.05	TSM-195 DC01A.05
Peak Power Watts-P _{MAX} (Wp)	185	190	195
Power Output Tolerance-P _{MAX} (%)	0/+3	0/+3	0/+3
Maximum Power Voltage-V _{MP} (V)	36.1	36.8	37.4
Maximum Power Current-I _{MPP} (A)	5.14	5.18	5.22
Open Circuit Voltage-V _{OC} (V)	44.6	45.1	45.6
Short Circuit Current-I _{sc} (A)	5.48	5.52	5.56
Module Efficiency η _m (%)	14.5	14.9	15.2

Values at Standard Test Conditions STC (Air Mass AM1.5, Irradiance 1000W/m², Cell Temperature 25°C).

ELECTRICAL DATA @ NOCT	TSM-185 DC01A.05	TSM-190 DC01A.05	TSM-195 DC01A.05
Maximum Power (W)	136	140	143
Maximum Power Voltage (V)	33.2	33.8	34.3
Maximum Power Current (A)	4.10	4.14	4.18
Open Circuit Voltage (V)	41.3	41.7	42.2
Short Circuit Current (A)	4.41	4.44	4.47

NOCT: Irradiance at 800W/m², Ambient Temperature 20°C, Wind Speed 1M/s.

MECHANICAL DATA

Solar cells	Monocrystalline 125 x 125mm (5 inches)
Cell orientation	72 cells (6 x 12)
Module dimension	1581 x 809 x 40mm (62.24 x 31.85 x 1.57 inches)
Weight	15.6kg (34.4 lb)
Glass	High transparency solar glass 3.2mm (0.13 inches)
Frame	Anodized aluminium alloy
J-Box	IP 65 rated
Cables / Connector	Photovoltaic Technology cable 4.0mm ² (0.006 inches ²), 900mm (35.4 inches), MC4

TEMPERATURE RATINGS

Nominal Operating Cell Temperature (NOCT)	46°C (±2°C)
Temperature Coefficient of P _{MAX}	- 0.41%/K
Temperature Coefficient of V _{OC}	- 0.31%/K
Temperature Coefficient of I _{sc}	0.051%/K

MAXIMUM RATINGS

Operational Temperature	-40~+85°C
Maximum System Voltage	1000V DC(IEC)/600V DC(UL)
Max Series Fuse Rating	10A

WARRANTY

10 year workmanship warranty
25 year linear performance warranty
(Please refer to product warranty for details)

PACKAGING CONFIGURATION

Modules per box: 23 pcs
Modules per 40' container: 644 pcs

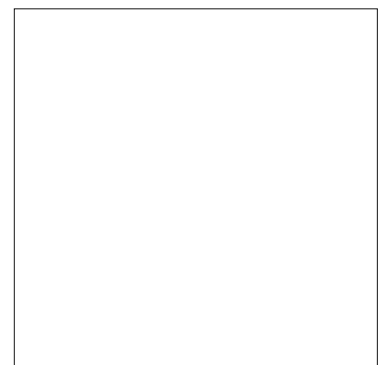

TSM_EN_Feb_2012