

TP300 series

72-cell multi-crystalline solar photovoltaic modules



Manufactured in India on leading edge module production line using world class processes



Reliability under extreme weather conditions, certified to withstand snow loads of up to 5,400 Pa



Peace of mind guaranteed by Tata Power Solar 25 year linear module warranty



Reduced risk of failure – warranty claims of less than 0.07% over two decades



Greater energy generated due to positive power tolerance of up to 5W



TUV and UL certified Potential Induced Degradation free modules*

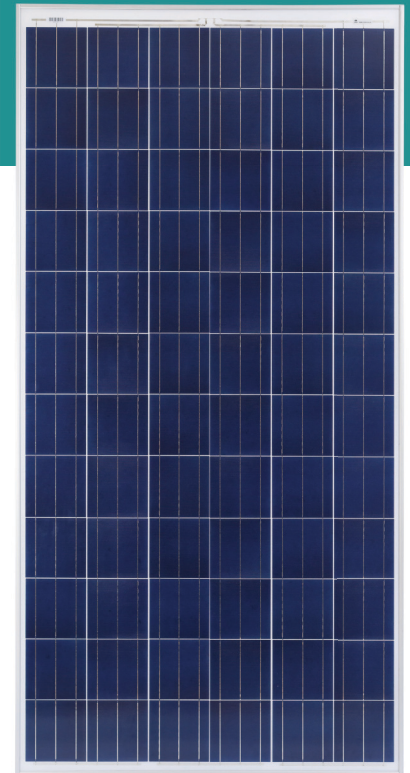

PRODUCT FEATURES

- 72 cell configuration with wattage ranging from 280 to 310W
- High fill factor for improved energy conversion efficiency
- Cells sorted by power and current to minimize mismatch losses in the field
- Electroluminescence tested for micro-cracks
- Highly reliable IP67 rated junction box
- MC4/MC4 compatible cable connectors
- Torsion and corrosion resistant with anodized aluminium frame
- Unique back sheet design for high resistance to moisture ingress
- Enhanced reliability through use of distinctive encapsulant and back sheet
- Ultra-soft interconnect with stress relief for enhanced reliability
- Optimized edge clearance for high quality rugged design

CERTIFICATIONS



Certified to IEC 61730, IEC 61215, IEC 61701, IEC62716, UL 1703 and REACH standards



WARRANTY

Product warranty: 10 year warranty on material and workmanship
Power warranty: 25 year linear power output warranty

Warranties are subject to the Terms and Conditions as per the Tata Power Solar Standard Warranty Document. Certifications may vary by module

About Tata Power Solar

Tier 1** bankable module manufacturer*** with 25 year history

Backed by \$100B Tata Group; eliminates need for expensive 3rd party insurance

BP Solar heritage of state-of-the-art technology and stringent quality processes

Over 700 MW of modules shipped globally

Highest standards of quality and management (ISO 9001, 14001 and OHSAS 18001)

* PID free certified modules available on order
** Rated tier-1 bankable by Green Tech Media Research
*** Bankability verified by third party auditors like Black & Veatch

Modules in the TP300 series TP280 TP285 TP290 TP295 TP300 TP305 TP310

Electrical parameters at standard test conditions (STC)*

Nominal power output (W)	280	285	290	295	300	305	310
Power tolerance (W)	0 ~ +5	0 ~ +5	0 ~ +5	0 ~ +5	0 ~ +5	0 ~ +5	0 ~ +5
Module efficiency (η%)	14.10	14.35	14.60	14.85	15.10	15.25	15.63
Voltage at P _{MAX} V _{MPP} (V)	36.1	36.3	36.4	36.5	36.6	36.8	37.3
Current at P _{MAX} I _{MPP} (A)	7.78	7.88	7.97	8.09	8.20	8.30	8.33
Open-circuit voltage V _{OC} (V)	44.5	44.6	44.7	44.7	44.8	44.8	45.1
Short-circuit current I _{SC} (A)	8.33	8.39	8.45	8.58	8.71	8.81	8.91

Electrical parameters at NOCT

Power output P _{MAX} (W)	201.6	205.2	208.8	212.4	216.0	219.6	223.2
Voltage at P _{MAX} V _{MPP} (V)	31.8	31.9	32.0	32.1	32.2	32.3	32.8
Current at P _{MAX} I _{MPP} (A)	6.35	6.43	6.52	6.61	6.71	6.81	6.83
Open-circuit voltage V _{OC} (V)	39.2	39.3	39.3	39.4	39.4	39.4	40.3
Short-circuit current I _{SC} (A)	7.03	7.10	7.17	7.21	7.24	7.27	7.41

Temperature coefficient characteristics

NOCT (°C)	47 ± 2
Module efficiency (%/°C)	-0.06 ± 0.01
Temperature coefficient of P _{MAX} (%/°C)	-0.4048
Temperature coefficient of V _{OC} (%/°C)	-0.2931
Temperature coefficient of I _{SC} (%/°C)	0.0442

Operating conditions

Maximum system voltage (UL & IEC) (V)	1000 & 1000
Maximum series fuse rating (A)	20
Limiting reverse current (A)	20
Operating temperature range (°C)	-40 and +85
Maximum static load (snow or wind)	113 psf (5400 Pa)

Module general characteristics

Module dimensions L x W x H (mm)	1984 x 1000 x 40
Module weight (approx) (kg [lbs])	24 [52.91]
Number of cells & size	72 cells & 156mm
Frame material	Anodized aluminium
Glass	3.2mm ARC
Junction box	IP67 rated
Cable connector	MC4/MC4 compatible (4mm ²)

Packaging details

Number of modules per pallet	25
Number of pallets per 40ft container	22
Box weight (kg)	630
Box dimensions L x W x H (mm)	2054 x 1135 x 1182

Technical Drawing** Dimensions in mm

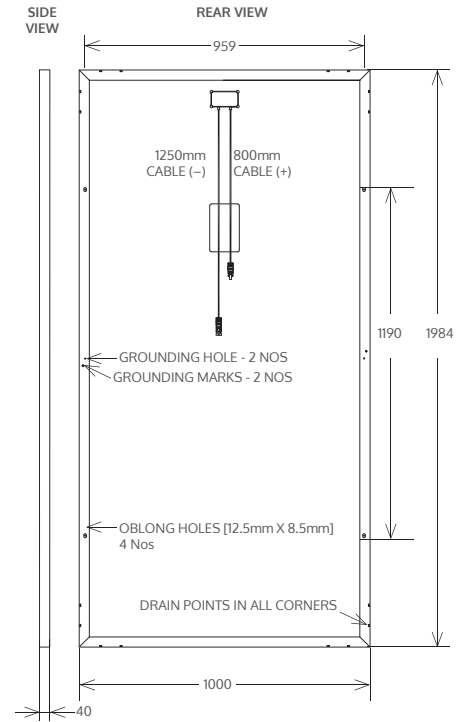

IV curve at multiple temperatures

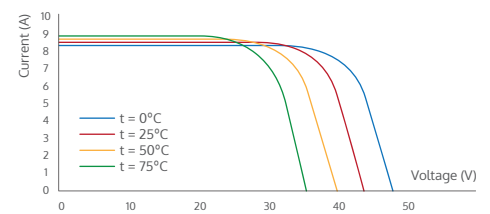

IV curve at multiple irradiance

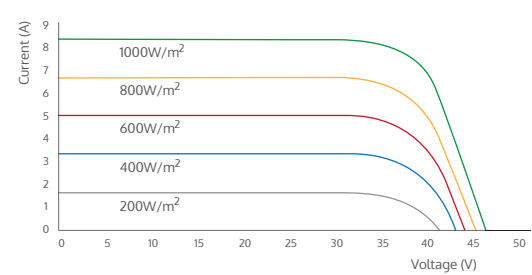

* Irradiance of 1000W/m², spectrum AM of 1.5 and cell temperature of 25°C
Best in class AAA solar simulator (IEC 60904-9) used, power measurement tolerance ±3%

** Tolerance for dimensions -3/+3mm
Tolerance for cable length 0/+50mm
Frame type any of lock or screw

Listed specifications are subject to change without notice.

Tata Power Solar is committed to enabling solar everywhere and bringing the power of the sun to people in the most efficient and cost effective way possible.



For sales, service and other enquiries, email us modules.solar@tatapower.com

www.tatapowersolar.com